

Kerb Specification:
 The X-One rooflight kerb is constructed from extruded uPVC sections, white in colour

Typical Glazing Specification:
 2mm thick polyester powder coated aluminium with 16mm structured polycarbonate internal liner

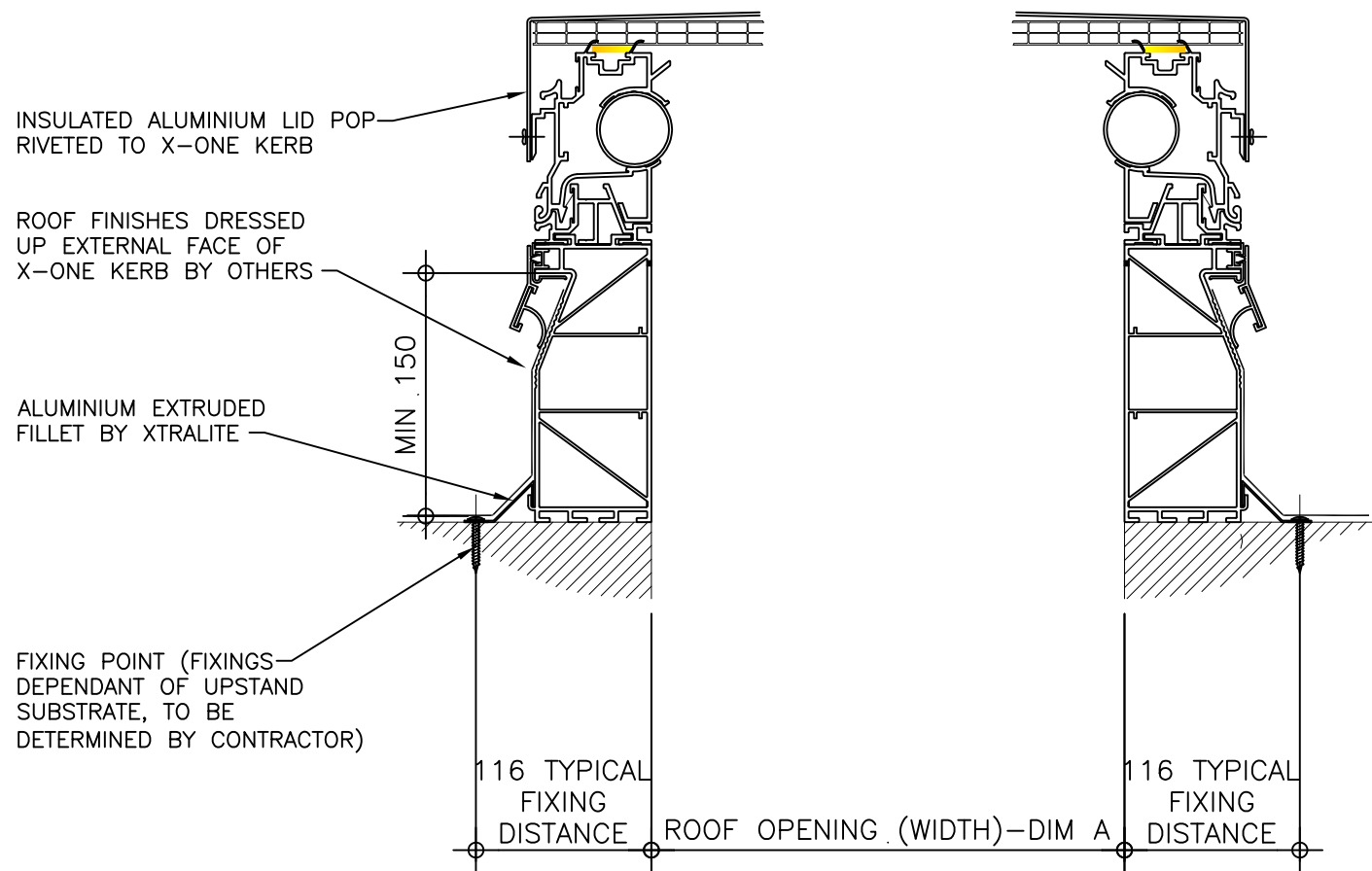

SECTION A - A

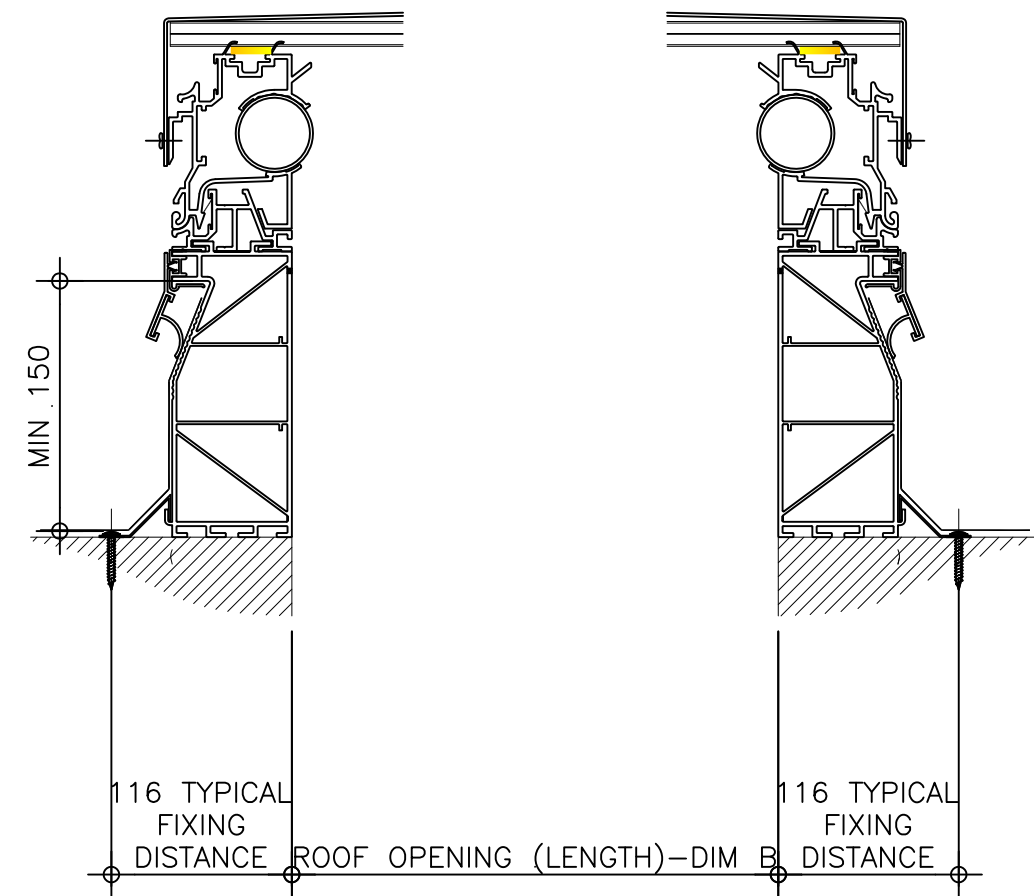

SECTION B - B

REV:	DATE:	DESCRIPTION:	DRN BY	DESCRIPTION:					
1	18.12.13	All X-One-C drawings revised	DL	Unventilated uPVC upstand fixed direct to insulated roof with insulated solid lid (aluminium).					
0	22.03.12	Issued for approval / comments	IW	DRAWN BY:	CREATION DATE:	CHECKED BY:	SCALE(S)	REVISION:	
				IW	18-Dec-13	DL	1:5 @ A3	1	
				Xtralite (Rooflights) Limited Spencer Road, Blyth Industrial Estate, Blyth, Northumberland, NE24 5TG T:01670 354 157 F:01670 364 875 E:sales@xtralite.co.uk W:www.xtralite.co.uk					DRG No. XT-X1-C-00-ISL