

**Kerb Specification:**  
 The X-One rooflight kerb is constructed from extruded uPVC sections, white in colour.  
 Metal foot polyester powder coated:-  
 Colour: White  
 RAL: 9910 Gloss

**Typical Glazing Specification:**  
 Outer - 6mm thick clear toughened glass  
 Core - 16mm thick air filled cavity  
 Inner - 6.4mm thick clear laminated low 'E' glass

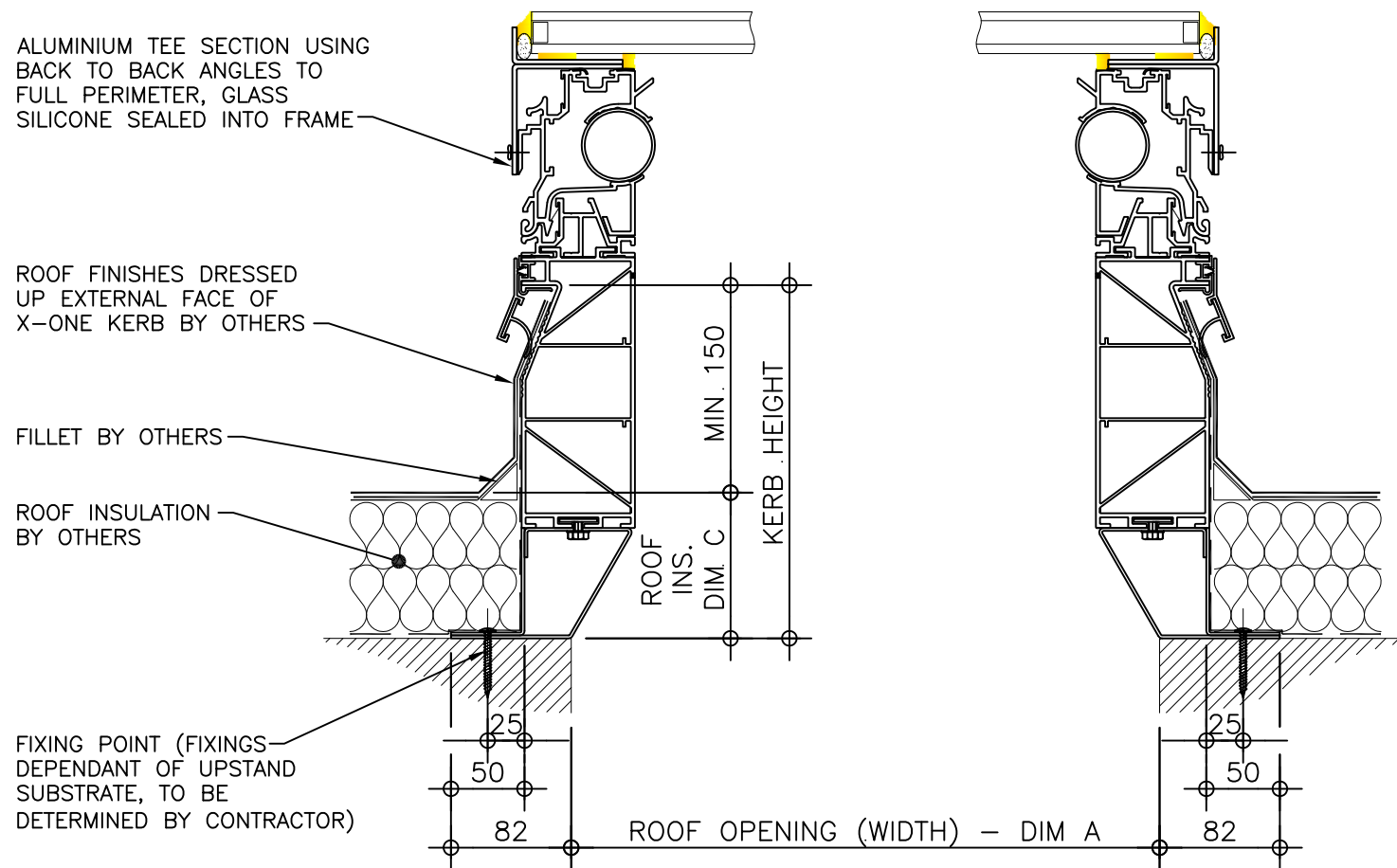

**SECTION A - A**

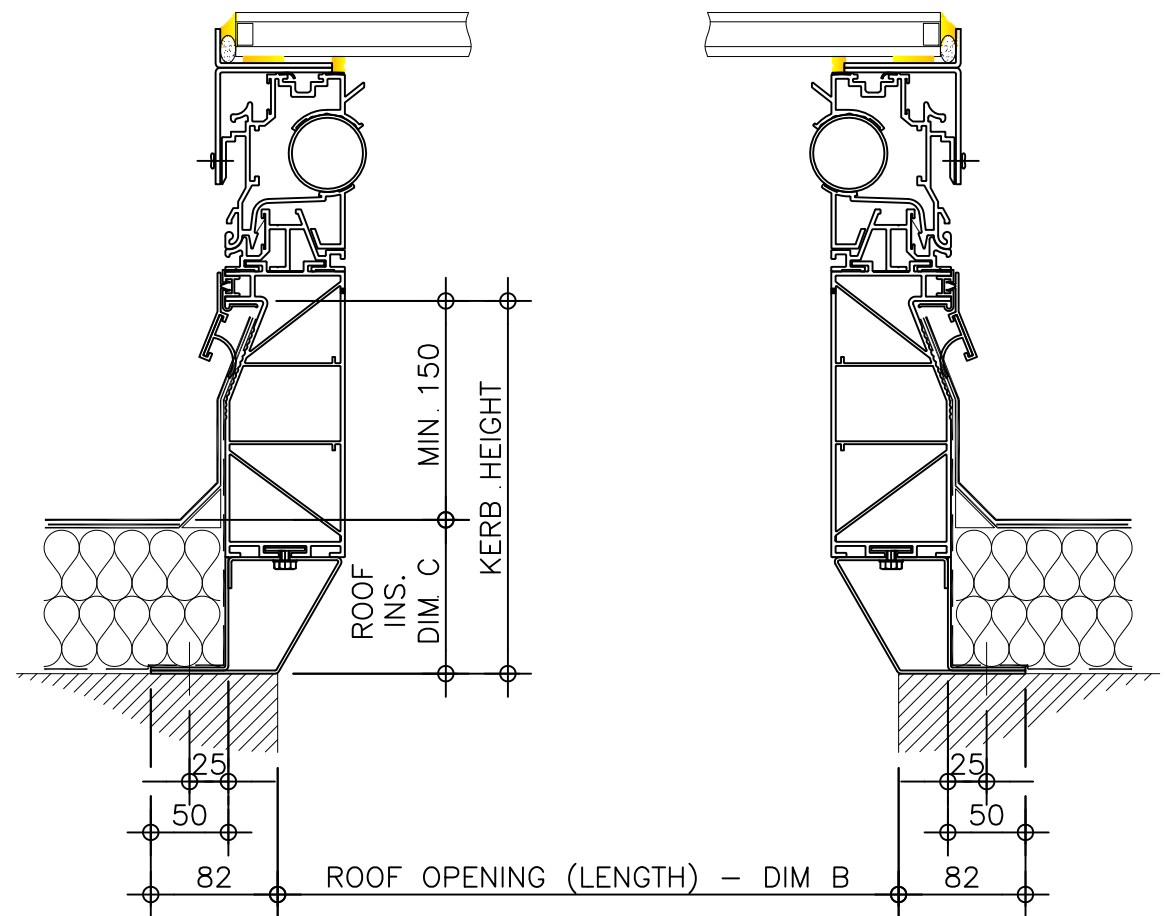

**SECTION B - B**

REV:	DATE:	DESCRIPTION:	DRN BY	DESCRIPTION:				
1	18.12.13	All X-One-A drawings revised	DL	Unventilated uPVC upstand with flexible base kerb, fixed direct to roof with flat double glazed glass lid.				
0	22.03.12	Issued for approval / comments	IW					
				DRAWN BY:	CREATION DATE:	CHECKED BY:	SCALE(S)	REVISION:
				IW	18-Dec-13	DL	1:5 @ A3	1
				<b>Xtralite (Rooflights) Limited</b> Spencer Road, Blyth Industrial Estate, Blyth, Northumberland, NE24 5TG T:01670 354 157 F:01670 364 875 E:sales@xtralite.co.uk W:www.xtralite.co.uk				DRG No. <b>XT-X1-A-00-IGLF</b>